



SPP

*Southwest
Power Pool*

***Facility Study for Generation
Interconnection Request
GEN – 2002 – 019***

***SPP Coordinated Planning
(#GEN-2002-019)***

February 2005

Summary

Southwestern Public Service Company (SPS) (d/b/a Xcel Energy, Inc.) performed the following study at the request of the Southwest Power Pool (SPP) for Generation Interconnection request Gen-2002-019. The request for interconnection was placed with SPP in accordance SPP's Open Access Transmission Tariff, which covers new generation interconnections on SPP's transmission system.

Pursuant to the tariff, SPS was asked to perform a detailed facility study of the generation interconnection requests to satisfy the Facility Study Agreement executed by the requesting customer and SPP.

The Customer requested that the study cover using the GE 1.5 sle wind turbines for an anticipated interconnection of 160 MW.



FACILITIES STUDY

For

>OMITTED TEXT<

160 MW Wind-Generated Energy Facility
Carson County, Texas
SPP #GEN-2002-019

February 15, 2005

Xcel Energy Services, Inc.
Transmission Planning

Executive Summary

>Omitted Text< (the “Requester”) has requested the interconnection of the Requester’s Wind Farm >Omitted Text< to Southwestern Public Service Company (SPS) (d/b/a Xcel Energy, Inc) 230 kV transmission line. This facility will interconnect to the 230 kV transmission circuit between Nichols Station, in Amarillo, TX and Grapevine Interchange in Gray County, TX. The Southwest Power Pool (SPP) evaluated the request to interconnect this wind energy facility to the SPS transmission system in a System Impact Study completed in November 12, 2004. On January 18, 2005 the requester revised their request for this facility study by changing the selected wind turbine to the GE 1.5 sle wind turbine. Therefore, this facility study only applies to the requester’s wind energy facility consisting of 106 individual GE 1.5 sle wind turbines with a rated output of 1.5 MW each, with the nominal output of this facility being 159 MW. The proposed in-service date for the project is 2008.

A new switching station will be constructed that will tap the existing SPS 230 kV transmission circuit K-53 approximately 17 circuit miles east of Nichols Station. The new switching station will consist of a 230 kV ring bus with a 230 kV tap to the requester’s wind farm allowing for the transmission of wind energy from the requester’s substation to the SPS transmission grid.

A Certificate of Convenience and Necessity (CCN) from the Public Utility Commission of Texas is not required for the construction of the new switching station.

The Requester is responsible for the cost of the Requester’s Interconnection Facilities, inclusive of all construction required for the 230 kV transmission line from the Requester’s substation to the new SPS switching station.

Xcel Energy’s transmission design group will require an engineering review of the requester’s transmission line design prior to any construction by the requester (or its contractor) on the customer owned 230kV transmission line. It is the requester’s responsibility to initiate the design review in a timely manner before any construction of the 230kV transmission line begins.

Xcel Energy requires the Interconnection Customer to construct the Interconnection Facilities in compliance with the latest revision of the Xcel Energy Interconnection Guidelines for Transmission Interconnection Producer-Owned Generation Greater than 20 MW. This document describes the technical and protection requirements for connecting new generation to the Xcel Energy operating company transmission system and also includes commissioning, operation, and maintenance guidelines. Xcel Energy will also require that the Interconnection Customer be in compliance with all applicable criteria, guidelines, standards, requirements, regulations, and procedures issues by the North American Electric Reliability Council, (NERC), Southwest Power Pool, and Federal Energy Regulatory Commission or their successor organizations.

It is anticipated that the construction of the new switching station, for the acceptance of wind generated electric energy from the Requester’s Wind Farm, will require approximately 13 months for completion. The cost of these upgrades, inclusive of the Requester’s cost for the

Interconnection Facilities required for the interconnection of this new wind energy generation facility, is shown below:

| | |
|-------------------------------------------|---------------------|
| Stand-alone Network Upgrade: | \$ 3,006,894 |
| Network Upgrade: | \$ 432,567 |
| Interconnection Facilities ¹ : | \$ 10,000 |
| <hr/> | |
| Total: | \$ 3,449,461 |

A detailed description of all costs associated with the construction of this new SPS switching station is shown in Table 2.

¹ Direct Assigned Cost To Requester

Discussion

General Description

The new switching station required to connect the requestor's wind-generated energy facility will be located adjacent to the existing Nichols Station to Grapevine Interchange 230 kV transmission line. The new switching station will consist of a three breaker 230 kV ring bus design with expansion capability to a breaker and a half configuration. The existing transmission line will be routed in and out of the new switching station with 230 kV breakers on both lines towards Nichols Station and Grapevine Interchange, and on the new customer owned 230 kV transmission line.

General Description of Modifications and New Facilities

1. **Construction of New Switching Station:** See Figure A - 2 in Appendix A for one-line diagram and Figure A - 1 for a plan view of the station.
 - 1.1. **Location:** The new 230 kV switching station will be constructed at the interception point to the Xcel Energy transmission circuit K-53, located in the southwest corner of the southwest quarter of Section 36 Block T of the H&W Survey of Carson County, Texas (approximately 17 circuit miles east of the Nichols Station). See Figure A – 1 for a map of the area.
 - 1.2. **Bus Design:**
 - 1.2.1. The 230 kV ring bus will be built as a 3-breaker ring expandable to a 2 string breaker-and-a-half with 4 terminals. In the switching station there will be three dead-end towers on the 230 kV, 11 switches on structures, three sets of 230 kV potential transformers (PT) on stands, and one 230 kV PT will be installed as a backup power source for station power.
 - 1.3. **Control House:** A control house approximately 24 feet by 36 feet will be installed to contain the metering, protection and control devices, terminal cabinets, and any fiber-optic cable terminations, etc.
 - 1.4. **Line Reactors:** None.
 - 1.5. **Security Fence:** The switching station will have a 7-foot chain-link fence with steel posts set in concrete, with 1-foot of barbed wire on the top in a "V" configuration. The enclosed area will be approximately 400' × 300', with a rock yard surface.
 - 1.6. **Ground Grid:** A complete ground-grid will be installed per ANSI/IEEE STD 80-2000, with our standard 4/0 copper ground mesh on 40-foot centers with ground rods and 20-foot centers in corners and loop outside of fence.

- 1.7. **Site Grading:** Company contractor, per company specifications, will perform initial site grading and erosion control of the new switching station. Soil compaction shall be not less than 95% of laboratory density as determined by ASTM-D-698.
- 1.8. **Station Power:** A 133kV/120-240 volt transformer tapped off of the 230 kV bus will provide station power. A backup station power source will be taken from local distribution, if it is available, or a generator will be installed if no distribution service is available. Additionally, a flip-flop to automatically transfer the station power will be installed.
- 1.9. **Relay and Protection Scheme:** The new switching station to the Nichols Station 230 kV line relaying will be directional comparison over power line carrier. A SEL 321-1 and a separate segregated phase comparison transmission line protection system with distance backup protection will be used with a leased phone circuit. An SEL 279H-2 with a SEL 351 relay will be used for sync check and re-closing, along with an SEL 501-0 for breaker failure.

The new switching station to Grapevine Interchange 230 kV line relaying will utilize the same type of equipment as that of the Nichols Station 230 kV line.

On both the Nichols Station and Grapevine Interchange lines there will be three coupling capacitor voltage transformers (CCVT) for line conditions. Line tuning units and wave traps will also be installed for the power line carrier communications.

The batteries will be our standard set of 306 or 204 AH Varta batteries with a 35 or 25 amp charger.

At Nichols Station or Grapevine Interchange, carrier frequencies will need to be changed on the existing wave traps and line-tuning units, to maintain carrier frequency separation.

- 1.10. **Revenue Metering:** On the 230 kV line to the Requester's substation, a billing meter will be installed along with an ION 8400 meter unit, ANSI C12.1 accuracy class 0.2 (3 PTs IEEE C57.13 accuracy class 0.3 and 3 CTs IEEE C57.13 accuracy class 0.15) for full 3 phase 4-wire metering. The metering unit will have 3000/1800:1 PTs and 200/400:5 CTs. There will be two meters one will be primary and the other will be back-up, and each will have full 4 quadrant metering. Pulses out of the primary billing meter will be sent via SCADA to the Amarillo Control Center.
- 1.11. **Disturbance Monitoring Device:** A disturbance-monitoring device will be installed to monitor and record disturbances on the 230 kV equipment.

1.12. **Communications:** A high-speed phone circuit will be required between the new switching station and both Nichols Station and Grapevine Interchange, which will provide communications for line relaying.

The RTU will be our standard large 5700 RTU with communications. An SEL 2020 will be installed for relay communications and other functions as required.

The Disturbance Monitoring Device will also have a dedicated phone circuit

Communications from the switching station to the Amarillo Control Center will consist of a 4-wire telephone data circuit provided by the Requester, if it is available. If it is not available, some type of communications will have to be installed, at the Requester's expense, to get the metering data to the Amarillo Control Center, along with the RTU information.

A station telephone will be installed in the control house. A telephone switch will be installed to transfer between the SEL-2020 and the billing meters along with the station talk service.

A schematic outlining the proposed communications is provided below:

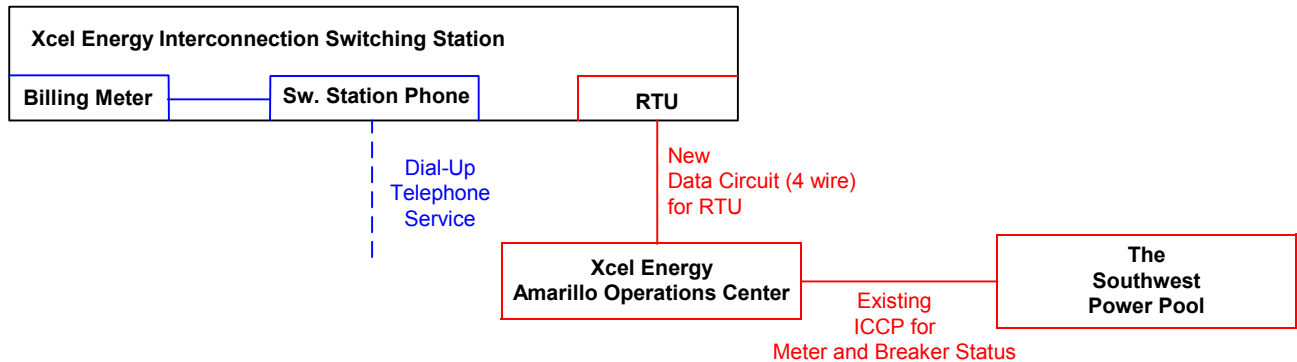

2. Transmission Line:

The Requester will construct, own, operate, and maintain the new customer owned 230 kV transmission line from the Requester's substation to this new SPS switching station. Figure A - 5 shows the Point of Interconnection and Change of Ownership.

It is the requester's responsibility to initiate the design review in a timely manner before construction of the 230kV transmission line begins. If the review has not been made or the design is deemed inadequate, the termination into the new SPS 230 kV switching station will be delayed until the matters are resolved. Xcel Energy will not be held responsible for these delays.

2.1. **230 kV Line Taps:** An existing Xcel Energy overhead 230 kV transmission line (K-53) will be tapped in and out of the new switching station centered on structure 124. The location is in the SW Corner of the SW 1/4 of Section 36; Block T of the H&W Survey Carson County, Texas, with the GPS coordinates of the structure being 35° 23' 51"N,

101° 31' 7"W, and located on the north side of the south section boundary of Section 36.

Two overhead 230 kV taps will be constructed on the east and west sides of the switching station, dead-ending on 230 kV terminals within the new switching station. The existing 230 kV line between these two tap points will be removed such that power flows in and out of the proposed switching substation. See Figure A-3.

3. **Right-Of-Way:**

- 3.1. **New 230 kV Transmission Line Taps:** See Figure A-3 for location of line taps relative to switching station site.
- 3.2. **Permitting:** Currently, permitting for the construction of the new switching station is not required in the State of Texas.
- 3.3. **Switching Station Location:** The new switching station will be constructed adjacent to the existing 230 kV transmission circuit K-53, assuming the land can be procured from the landowner.

4. **Construction Power and Distribution Service:** Both Construction and Station power, in addition to any distribution service required for the Requester's wind-generated energy facility, are the sole responsibility of the Requester. **Xcel Energy, Inc. cannot provide station power (retail distribution service) for the Requester's substation if the location of the requester's substation lies outside of the Xcel Energy service area.**

5. **Project and Operating Concerns:**

Close work between the Transmission group, the Requester's Personnel and local operating groups will be imperative to have this project in service on the scheduled date.

6. Short Circuit Study Results:

The Short Circuit Analysis was performed internally by Xcel Energy Services to determine the available fault current at the 230 kV bus of the new switching station. These values may be used as a starting point for the determination of the available fault currents and interrupting capability of their facilities. The results are shown in Table 1, and the impedances are in per-unit at the specified voltage.

| Table 1: Short Circuit Information | | | | |
|-------------------------------------------|-------------------|----------|---------------------------------------|------------------------|
| Fault Location | Fault Current (A) | | Impedance (pu Ω) ² | |
| | Line-to-Ground | 3-Phase | Z ⁺ | Z ⁰ |
| New Switching Facility 230 kV Bus | 5,689.02 | 7,734.44 | 0.00384 + j 0.03223 | 0.01428 + j 0.06608 |

Estimated Construction Costs:

The projects required for the interconnection of the 160 MW wind energy generating facility consist of the projects summarized in the table below:

Table 2, Required Interconnection Projects

| Project | Description | Estimated Cost |
|----------------------------------------------------------------|----------------------------------------------------------------|---------------------|
| Stand-alone Network Upgrade | | |
| 1 | Ring Bus, 230 kV | \$ 2,754,894 |
| 2 | Station Power | \$ 116,000 |
| 3 | Disturbance Monitoring Device | \$ 100,000 |
| 4 | Right-of-Way Cost (station land, surveying, etc.) | \$ 36,000 |
| | Subtotal: | \$ 3,006,894 |
| Network Upgrade | | |
| 5 | Communications Cost | \$ 85,000 |
| 6 | Relay Modifications, Nichols Station and Grapevine Interchange | \$ 172,567 |
| 7 | 230 kV Transmission Line Work | \$ 175,000 |
| | Subtotal: | \$ 432,567 |
| Interconnection Facilities (at the Requester's Expense) | | |
| 8 | 230 kV Arresters | \$ 10,000 |
| | Subtotal: | \$ 10,000 |
| | Total Cost: | \$ 3,449,461 |

² Z⁺ – Positive Sequence Impedance in pu on a 100 MVA base

Z⁰ – Zero Sequence Impedance in pu on a 100 MVA base

7. Engineering and Construction Schedule:

It is anticipated that the switching station and all associated components will be constructed and ready to receive power from the Requester's wind farm approximately 13 months from the day an interconnection agreement is signed, unless prior arrangements have been made. This is the earliest Xcel Energy can initiate the project as a result of other scheduling considerations. An Engineering and Construction schedule is shown below:

| ID | Task Name | Duration | Year 1 | | | | | | | | | | | | Year 2 | | | | | | | | | | | | Year 3 | | | | | | | | | | | | | | | | | | | | | | | |
|----|--------------------------------------------------|-----------------|--------|----|------|---|---|---|---|---|---|---|---|----|--------|----|---|---|---|---|---|---|---|---|---|----|--------|----|---|---|---|---|---|--|--|--|--|--|--|--|--|--|--|--|--|--|--|--|--|--|
| | | | 11 | 12 | 1 | 2 | 3 | 4 | 5 | 6 | 7 | 8 | 9 | 10 | 11 | 12 | 1 | 2 | 3 | 4 | 5 | 6 | 7 | 8 | 9 | 10 | 11 | 12 | 1 | 2 | 3 | 4 | 5 | | | | | | | | | | | | | | | | | |
| 1 | Panhandle Wind Ranch Substation Project | 278 days | | | | | | | | | | | | | | | | | | | | | | | | | | | | | | | | | | | | | | | | | | | | | | | | |
| 2 | Signed Agreement | 1 day | 1/1 | ◆ | 1/1 | | | | | | | | | | | | | | | | | | | | | | | | | | | | | | | | | | | | | | | | | | | | | |
| 3 | Preliminary Engineering & material commitment | 8 wks | 1/6 | | | | | | | | | | | | 2/28 | | | | | | | | | | | | | | | | | | | | | | | | | | | | | | | | | | | |
| 4 | Order Breakers | 26 wks | 2/17 | | | | | | | | | | | | 8/15 | | | | | | | | | | | | | | | | | | | | | | | | | | | | | | | | | | | |
| 5 | Land Acquisition | 16 wks | 1/6 | | | | | | | | | | | | 4/25 | | | | | | | | | | | | | | | | | | | | | | | | | | | | | | | | | | | |
| 6 | Survey substation | 3 wks | 4/28 | | | | | | | | | | | | 5/16 | | | | | | | | | | | | | | | | | | | | | | | | | | | | | | | | | | | |
| 7 | Foundation design complete | 8 wks | 1/1 | | | | | | | | | | | | 2/25 | | | | | | | | | | | | | | | | | | | | | | | | | | | | | | | | | | | |
| 8 | Final Engineering - Drawing Revisions - Drafting | 12 wks | 1/1 | | | | | | | | | | | | 3/25 | | | | | | | | | | | | | | | | | | | | | | | | | | | | | | | | | | | |
| 9 | Dirt work & site preparation | 7 wks | 5/26 | | | | | | | | | | | | 7/11 | | | | | | | | | | | | | | | | | | | | | | | | | | | | | | | | | | | |
| 10 | Manifest Construction Drawings | 16 wks | 1/1 | | | | | | | | | | | | 4/22 | | | | | | | | | | | | | | | | | | | | | | | | | | | | | | | | | | | |
| 11 | Foundation work and Fence | 8 wks | 7/14 | | | | | | | | | | | | 9/5 | | | | | | | | | | | | | | | | | | | | | | | | | | | | | | | | | | | |
| 12 | Complete steel, bus work & wiring | 14 wks | 9/8 | | | | | | | | | | | | 12/12 | | | | | | | | | | | | | | | | | | | | | | | | | | | | | | | | | | | |
| 13 | Final station testing and inspection | 4 wks | 12/15 | | | | | | | | | | | | 1/9 | | | | | | | | | | | | | | | | | | | | | | | | | | | | | | | | | | | |
| 14 | Substation commissioning | 1 wk | 1/12 | | | | | | | | | | | | 1/16 | | | | | | | | | | | | | | | | | | | | | | | | | | | | | | | | | | | |
| 15 | Completion of Substation | 1 day | 1/23 | ◆ | 1/23 | | | | | | | | | | | | | | | | | | | | | | | | | | | | | | | | | | | | | | | | | | | | | |

All additional cost for work not identified in this study is the sole responsibility of the Requester unless other arrangements are made.

Appendix A

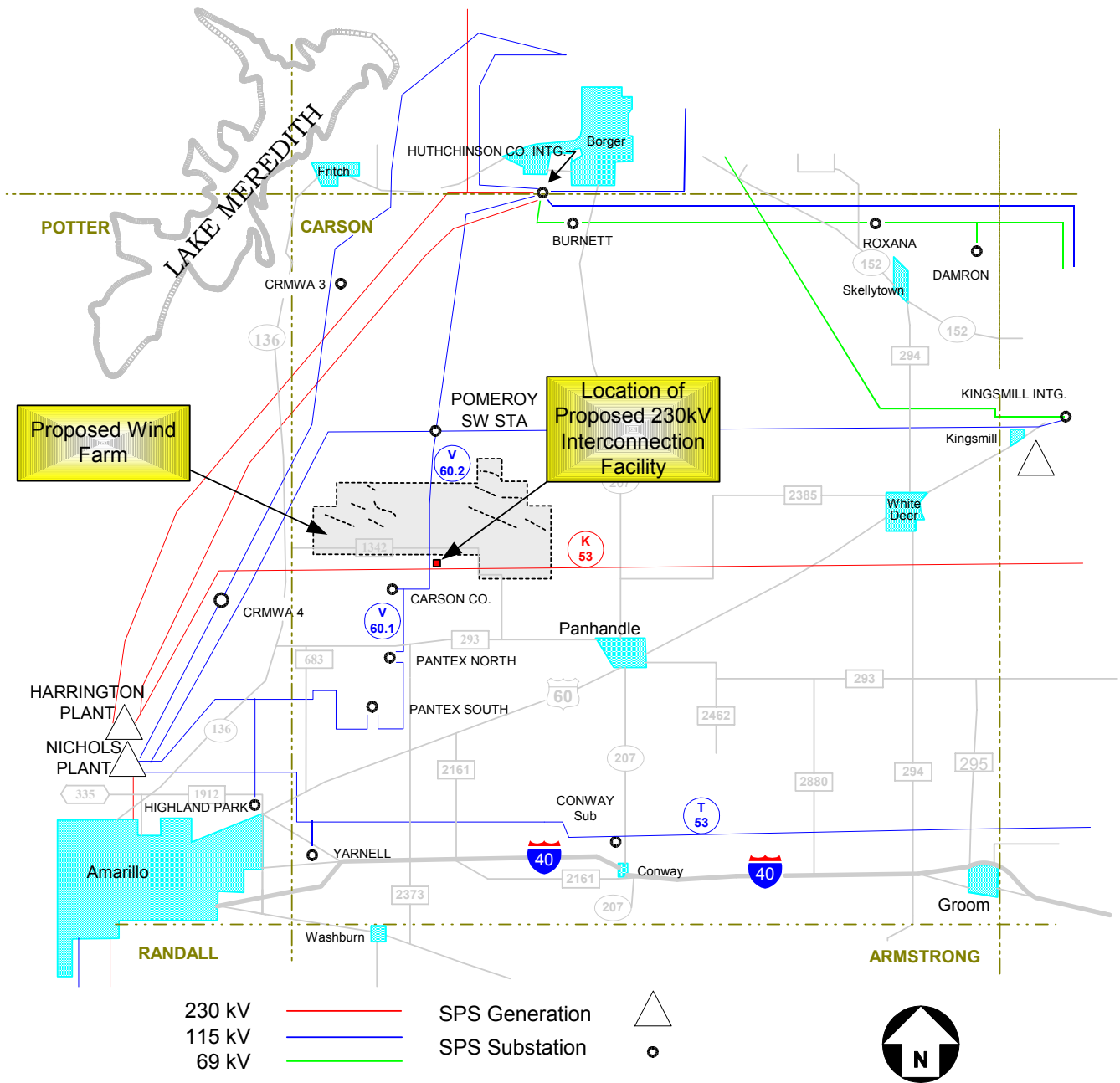

Figure A - 2 Proposed Interception Point to the Xcel Energy 230 kV Circuit K-53

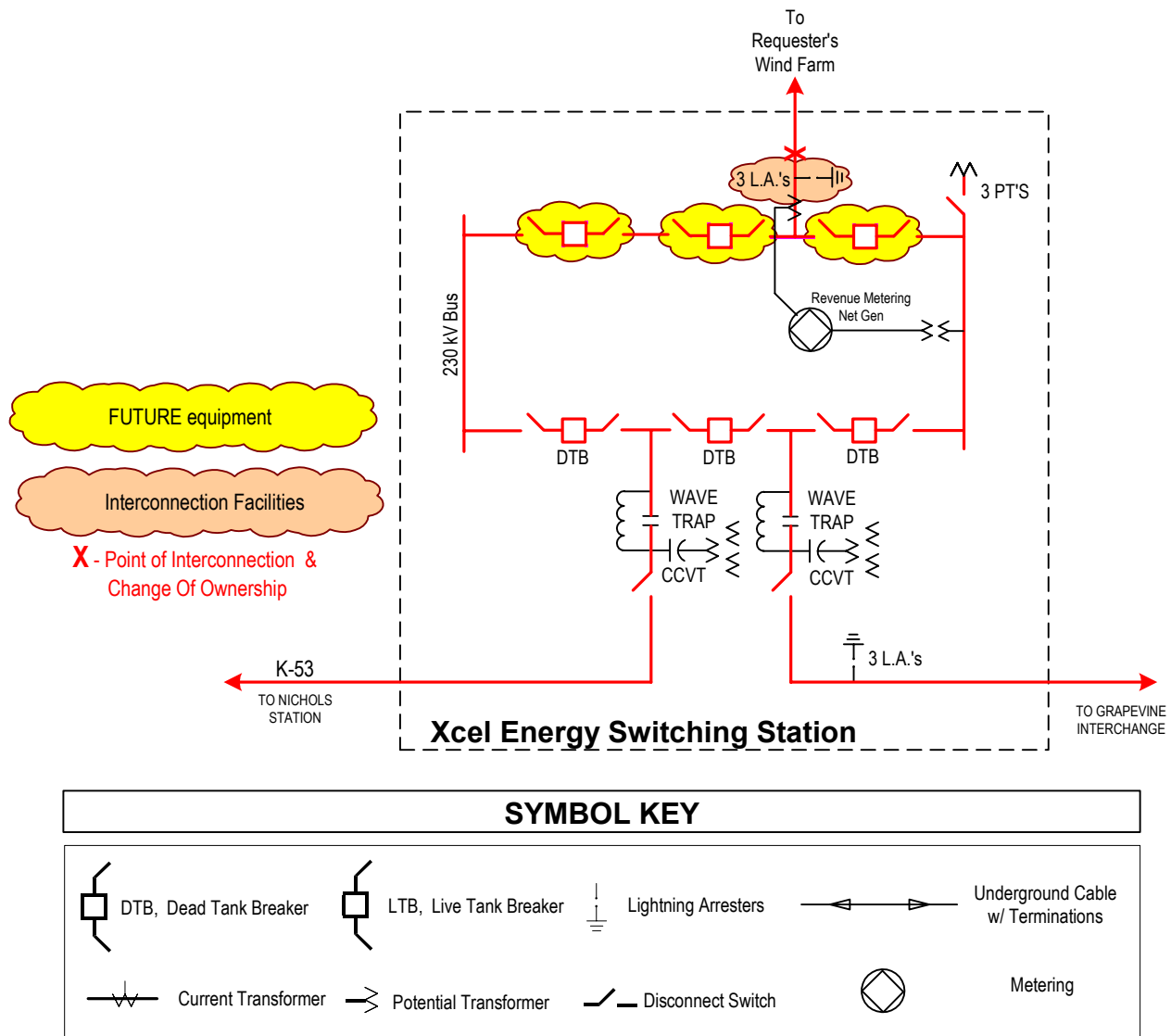

Figure A - 3 Switching Station One-line Diagram

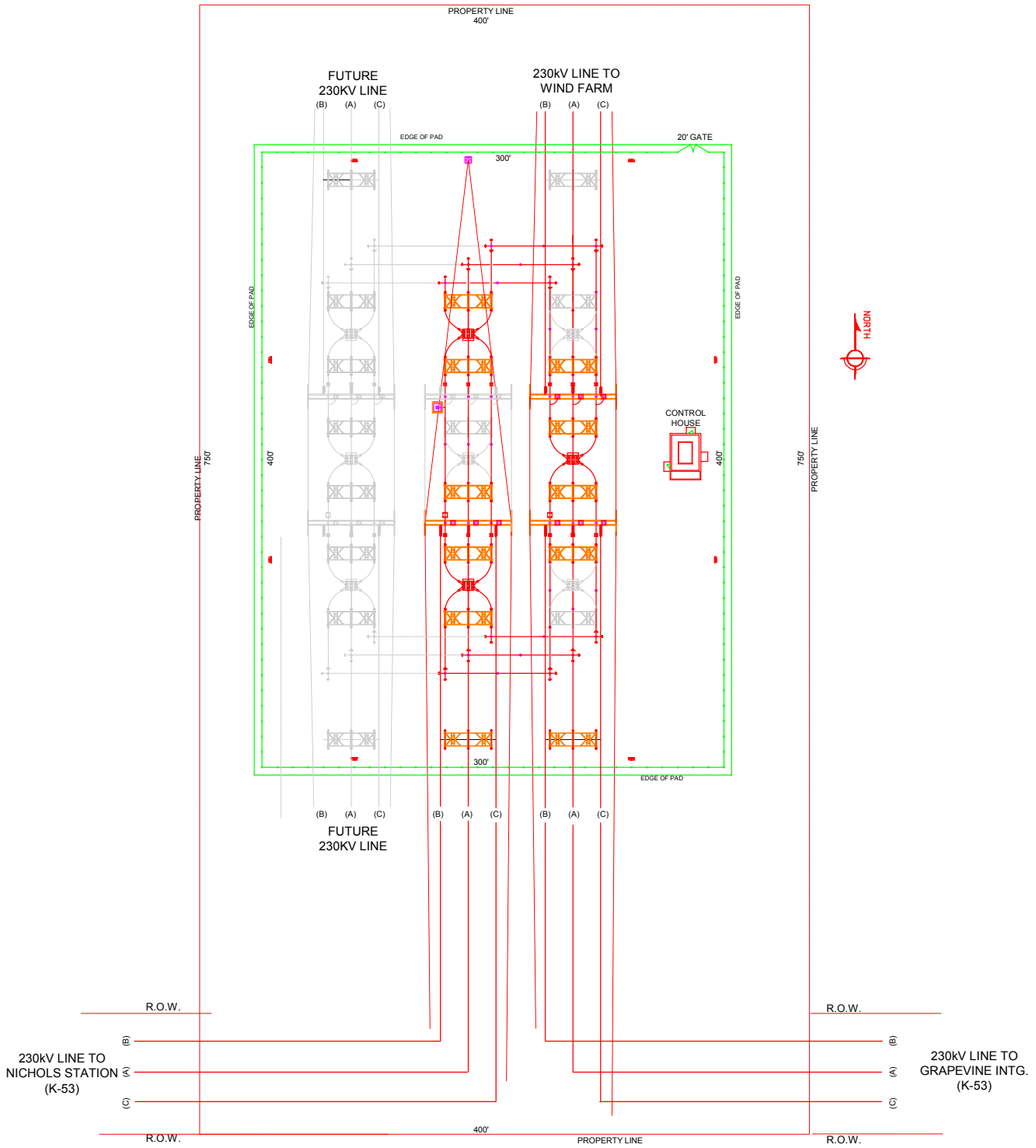
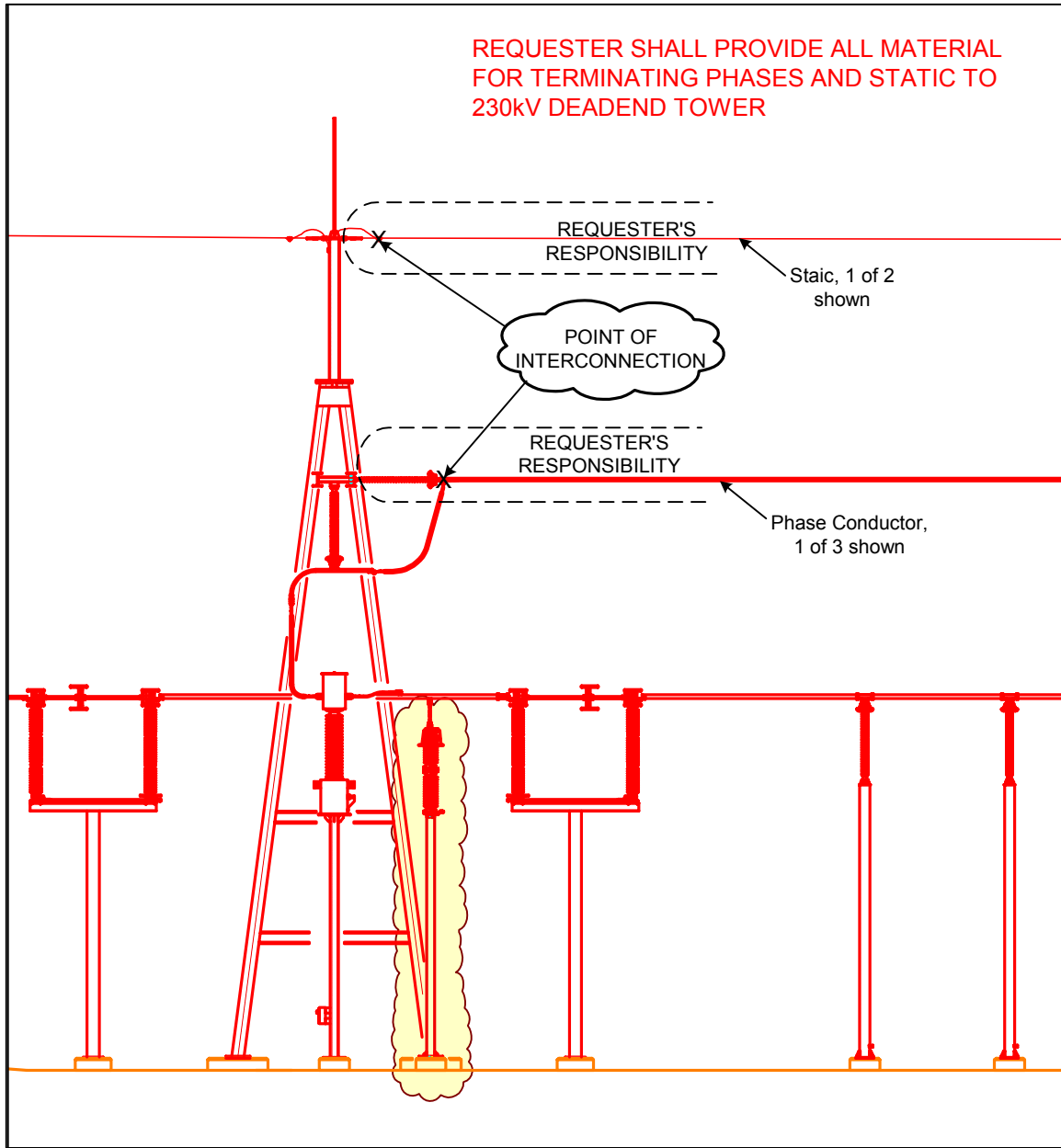

Figure A - 4 Proposed Line Taps on K-53



Interconnection Facilities

X - Point of Interconnection & Change of Ownership

Figure A - 5 Point of Interconnection & Change of Ownership